

# Domino V300+

The versatile thermal transfer printer for all flexible packaging



*The V300+ provides highly efficient thermal transfer overprinting on flexible packaging in high volume manufacturing environments. The printer does not require a controller. It is available with an optional, simple to use Touchscreen interface or can be used with existing OEM interfaces or PCs without the need for additional software.*

## **Reliable high quality coding**

---

The V300+ produces sharp, clear images and is ideally suited to high speed production lines. The equipment has been designed to integrate seamlessly into a range of flexible packaging machines including vertical and horizontal form/fill/sealers.

- Simple technology provides consistency with no maintenance requirements
- 300dpi print head produces sharp high quality text, bar codes, logos and Data Matrix codes
- Maximum print speed of 1400mm/sec with a print area of up to 128mm x 2700mm



**Excellent adhesion even after freezing**

## **Domino Ribbons**

---

Ribbons for V300+ are available in a wide range of grades, colours and widths and provide excellent performance for a wide range of web materials and industry applications.

Domino ribbons have been extensively tested to ensure that codes remain clearly legible when the manufacturers' products reach the end consumer. Tests on the printed code include freezing, steam-sterilisation, scratch-resistance and light fastness (resistance to fading through exposure to sunlight).



**Wide range of ribbon colours, grades and widths**

*The V300+ increases profitability and improves overall equipment effectiveness by running at high production speeds, maximising uptime and minimising rejects.*

## Key Benefits:

### Maximum availability (Uptime)

- Industry leading maximum ribbon length of 1400m reduces changeovers and maximises production uptime
- Maintenance free clutchless Dancing Arms provide ribbon tension control which prevents ribbon breakage and ensures responsiveness in high-speed applications
- Easy onboard label creation software and multiple message storage enables quick and simple message changeover
- Industry leading sealed electronics and protected print head ensures reliability in harsher environments
- Inbuilt heating element maximises print head life, minimises condensation in humid environments and improves system reliability



Print head protective cover prevents moisture and dust ingress

### Increased profitability

- Patented variable Ribbon Economy function reduces the amount of ribbon used per print without compromising on print resolution
- Ribbon retraction feature minimises the gap between prints ensuring maximum efficiency of ribbon usage
- Reduced inventory – printing additional product information can eliminate the need for pre-printed film

### Reduced rejects

- Low contact thermal transfer technology prevents risk of film perforation
- Onboard intuitive menu driven software minimises operator errors
- Optional 264mm (10.4") full-colour Touchscreen interface for simple operation

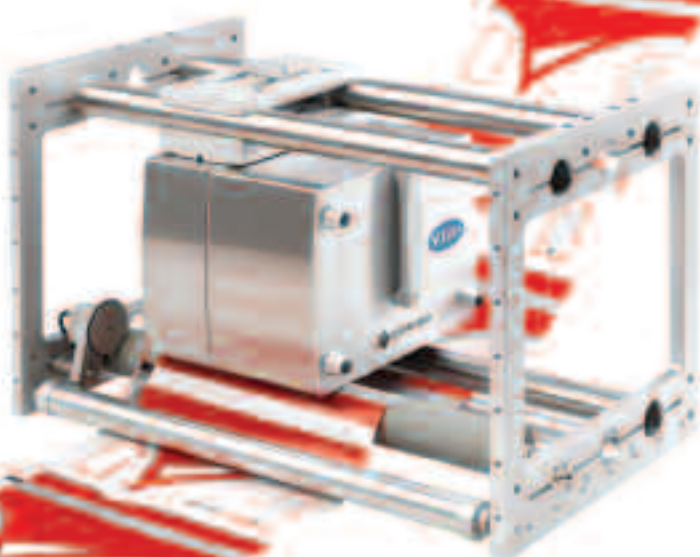

Simple integration with standard bracketry

The V300+ provides a versatile solution for all applications and production environments. It can be combined with TotalCare **plus** to provide a tailored support package.

### Versatility

- Built-in web server eliminates the need for a controller. Printer can be integrated with OEM user interface, PC or optional colour Touchscreen
- Wide range of ribbon grades, colours and widths to suit a variety of applications
- Intermittent and continuous printing modes in a single unit
- Quick change from left to right print flow direction without the need for additional components
- Clean technology ideally suited to all production environments including food and pharmaceutical



Excellent print qualities on a wide range of substrates

### TotalCare **plus**

V300+ can be complemented by TotalCare **plus**, a range of support packages allowing manufacturers to choose their support model from fully outsourced to a self-sufficient approach.



Clean technology ideally suited to all production environments including food and pharmaceutical

The V300+ offers a wide range of connectivity, data transfer and label creation options, allowing seamless integration into any production environment.

## Connectivity

### Built-in Web Server

- The printer has a built-in web server that allows all functionality to be controlled remotely via any interface running a standard internet browser
- Touchscreen option available, but not required.



### Network capability

- Built-in Ethernet port, enabling printers to be networked locally or enterprise wide



### External USB and SD card ports

The USB and SD card ports can be used to:

- Move messages and configurations between printers for local based set-up
- Back-up and restore messages and printer settings
- Upload printer information for service diagnostics
- Upload production data and download printer software upgrades



Optional Touchscreen available

## Label creation

- V300+ includes easy-to-use, on-board label creation software, but is also compatible with the following drivers: Windows®, LABELVIEW™, CODESOFT® and Connect +.

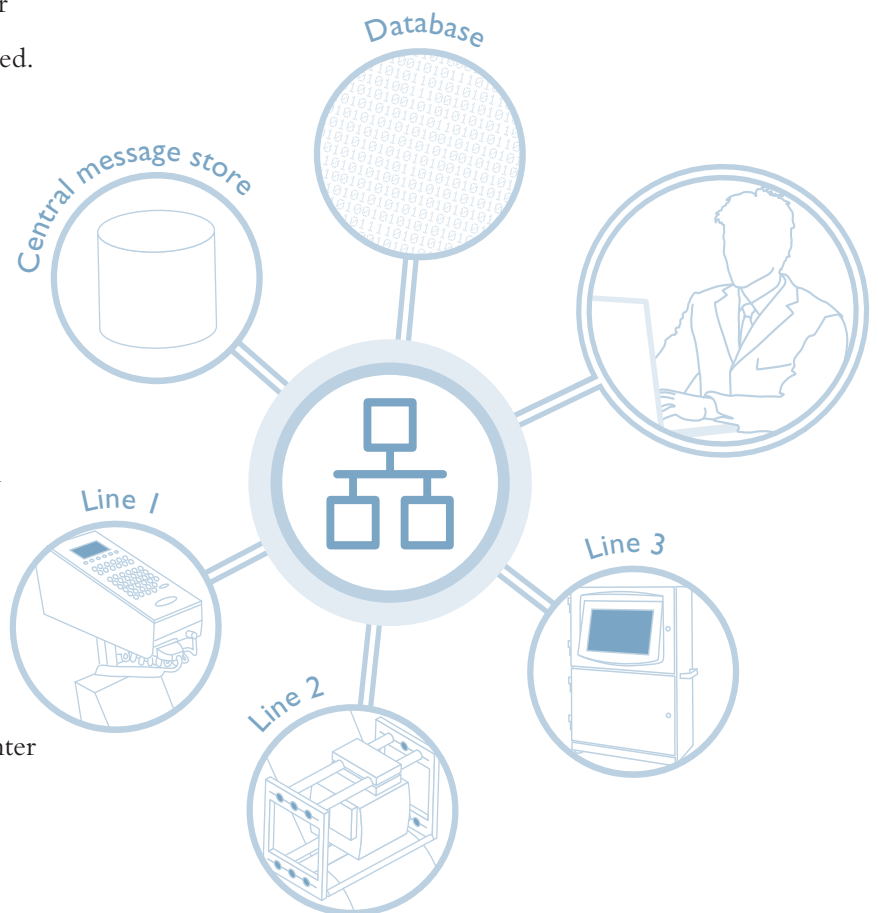

## Technical Specifications:

Product Specification	V300+ 2" Printer	V300+ 5" Printer
Printer Dimensions (mm)	260(W) x 190(H) x 225(D)	260(W) x 190(H) x 305(D)
Printer Weight (kg)	12 kg	14 kg
Print Area (IM Mode)	53 x 115mm	128 x 115mm
Print Area (CM Mode)	53 x 2700mm	128 x 1000mm
Ribbon Saving Features	Up to 60% Variable ribbon Economy (in CM Mode)	
Ribbon Retraction Offering	< 1mm gap between prints on used ribbon. Print overlap possible if message design allows.	
Print Speed*	Up to 1400mm/sec in CM Mode. Up to 5 prints per second in IM Mode (based upon 53 x 25mm print area)	
Print Density	300 dpi	
Character Control	Real Time Clocks, Text (in true type fonts), Logos, Bar Codes and Graphics	
Graphics Format	Monochrome PCX, Monochrome BMP	
User Interface	Web Browsable Graphical User Interface (GUI) (optional Touchscreen available)	
Label Creation	Full On Board Capability or EasyDesign PC Application. Also compatible with Windows®, LABELVIEW™, CODESOFT® and Connect+	
Connectivity	Ethernet, USB (for USB-stick), Secure Digital (on printer only), Digital I/O for host machine integration.	
Ribbon	Compatible with full range of Domino ribbon.	
Ribbon Width	Standards widths: 25mm, 55mm & 130mm.	
Beacon Alarm Outputs	Low Ribbon Warning, Ribbon end and other general fault conditions	
Printer IP Rating	Designed to IP44 (when printhead opening is covered)	
Touchscreen Option	10.4" SVGA full colour touch screen	
Touchscreen Dimensions (mm)	310(W) x 235(H) x 80(D)	

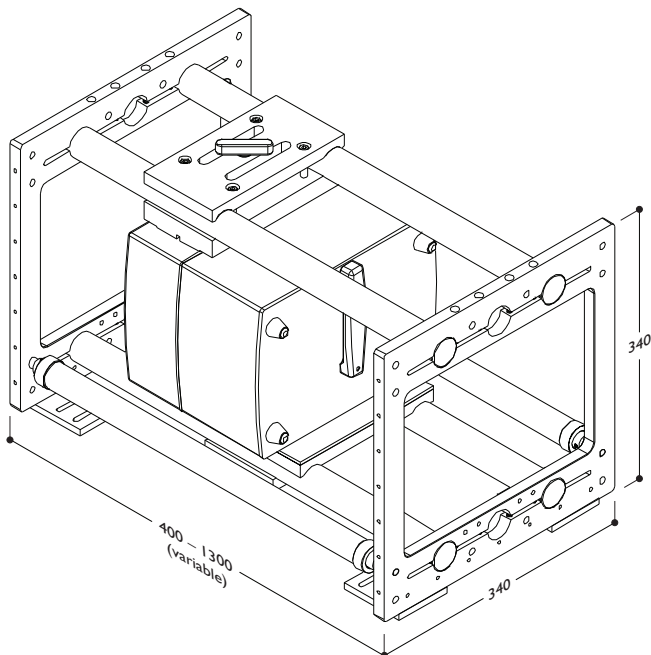

All dimensions in millimetres

Touchscreen IP Rating	Designed to IP65
Accessories	Full range of bracketry
Approvals	CE
Operating Environment	
Temperature	5 – 40 degrees celcius
Humidity	10 – 80 % without condensation
Electrical	115/230 VAC, 50/60 HZ, 300VA
Compressed Air	10 LT/MIN @ 6 BAR, MAX. CLEAN AIR

\*Dependent upon message size, substrate, ambient temperature and ribbon used

# V300+ Making more time for your business



## Ribbon Economy

Domino's patented Variable Ribbon Economy allows up to 60% saving in ribbon usage per print (the length of used ribbon is 40% of the length of the print).

This feature reduces time taken for ribbon changeovers and saves consumable costs – all with no reduction in print quality. The function can be adjusted in 1% increments to maximise the level of ribbon economy for your application.



## High Capacity Ribbon Rolls

V300+ ribbon rolls are 40% longer than those provided by other TTO manufacturers. This means less time is spent changing ribbons and more time is available for manufacturing.

## Simple Ribbon Mechanism

The ribbon mechanism uses maintenance free Dancing Arm technology which ensures responsiveness to high production/printing speeds.



## Ribbon Retraction

Ribbon Retraction controls the gap between each print on the ribbon to be less than 1mm, even if the gap between prints on the web is much larger.

This minimises ribbon waste and reduces the time needed for ribbon changeovers compared to other TTO and hot stamp systems.

# Domino Worldwide

Through an extensive global network of subsidiaries and distributors, Domino operates in over 120 countries. This network offers customers both sales support and access to highly skilled service teams, providing technical support packages to suit the varying production environments and customer requirements across the world.

## AUSTRALIA

Domino (Australia) Pty. Ltd.  
1, Neutron Place  
Rowville  
Melbourne  
Victoria 3178  
Australia  
Tel: + 61 3 9764 8485

## BELGIUM

Domino Benelux  
Uitbreidingstraat 84/3  
B-2600 Berchem  
Belgium  
Tel: +32 (0)3 218 2028

## CANADA

Domino Printing Solutions Inc.  
2751 Coventry Road  
Oakville  
Ontario  
L6H 5V9  
Tel: + 1 800 387 7972

## CHINA

Domino Coding Ltd.  
No. 1150 Yun Qiao Road  
Jin Qiao Export  
Processing Zone  
Pudong  
Shanghai 201206  
Tel: + 86 21 5050 9999

## FRANCE

Domino SAS  
ZA du Bel Air  
2 Rue Mege Mouriés  
78120 Rambouillet  
Tel: + 33 1 3046 5678

## GERMANY

Domino Deutschland GmbH  
Lorenz-Schott-Strasse 3  
55252 Mainz-Kastel  
Tel: + 49 61 34 25 050

## INDIA

Domino Printech India  
Private Limited  
167, Udyog Vihar Phase I,  
H.S.I.D.C Gurgaon -  
122016 Haryana  
Tel: + 91 124 400 7406

## MEXICO

Domino Printing México  
SA de CV  
Calle 3 No. 47 Local 6F Col.  
Industrial Naucalpan  
53370 Edo. De México  
Tel: + 52 55 5576 7979

## NETHERLANDS

Domino Benelux  
Ambachtsweg 8  
3991 LH Houten  
Tel: + 31 30 636 3333

## SOUTH KOREA

Domino Korea Pte Ltd  
1st-3rd Floor  
Rich Town Building  
#694 Bokjeong-dong,  
Sujeong-gu,  
Seongnam-city, Gyeonggi-do  
461-200  
Tel: + 82 2 797 1811

## SPAIN

Domino Amjet Ibérica S.A.  
Avenida Fuente Nueva No 14  
28700 S.S. de los Reyes  
Madrid  
Tel: + 34 91 654 2141

## UNITED ARAB EMIRATES

Domino UK Ltd  
P.O. Box 16984  
Jebel Ali Free Zone  
Dubai  
U.A.E.  
Tel: + 971 4 88 35003

## UNITED KINGDOM

Domino UK Ltd  
Bar Hill  
Cambridge  
CB23 8TU  
Tel: + 44 1954 782 551

## UNITED STATES OF AMERICA

Domino Amjet. Inc.  
1290 Lakeside Drive  
Gurnee  
Illinois 60031  
Tel: + 1 800 486 7414



ΚΩΔΙΚΟΠΟΙΗΣΗ · ΙΧΝΗΛΑΣΙΜΟΤΗΤΑ · ΔΙΑΧΕΙΡΙΣΗ ΠΑΡΑΓΩΓΗΣ

Αγ. Αθανασίου 17 Τ.Θ. 76  
19002 Παιανία  
marketing@theodorou.gr

Τηλ: 210 6690900  
Fax: 210 6640200  
www.theodorou.gr

[www.domino-printing.com](http://www.domino-printing.com)