

CombiChecker XS3 CC

A compact system



Colour touchscreen

Colour touchscreen with large 15" display for best visibility and easy operation.



Memory locations

allow for a quick and easy changeover to another product.



Metal detector

available in different sizes (pass width, pass height).



Pusher

Two rejecting devices ensure that metal-contaminated and off-weight products can be separately rejected.



In-line weighing and metal detection – in one process

With the proven "checkweigher plus metal detector" system GARVENS offers a perfect solution for manufacturers who care about their responsibilities especially in the food, pharmaceutical and cosmetics industries. It checks whether products are "on-weight" and free of metal contamination. Central article data editing at the weighing terminal of the checkweigher, quick and easy article changeover, rejection of off-weight and metal-contaminated products.

The combination of a XS3 CC with a metal detector is a powerful system with double function enabling manufacturers to come up to the quality assurance criteria as per FDA, part 11 or IFS. Hygienic and compact design.

Technical data

XS3 CC

– Weighing monitoring and metal detection

Whilst the checkweigher measures product weights fast and precisely, rejecting "out of tolerance" products, the metal detector reliably detects and rejects products contaminated by metal which could be a nut or bolt, metal particles, filings, staples, needles or wire pieces. The rejection of "bad" products is ensured by two rejecting devices – e.g. air jets, pushers or swing gates – so that metal-contaminated and off-weight products can be separately rejected.

An article changeover can be carried out quickly and easily on the weighing terminal of the checkweigher – a count of metal-contaminated products is displayed and recorded together with weight information on the terminal screen, or on a PC or laptop connected via an Ethernet network. The compact design ensures that the XS3 CC integrates into most production lines. The hygienic design meets strict food processing regulations and allows easy cleaning.

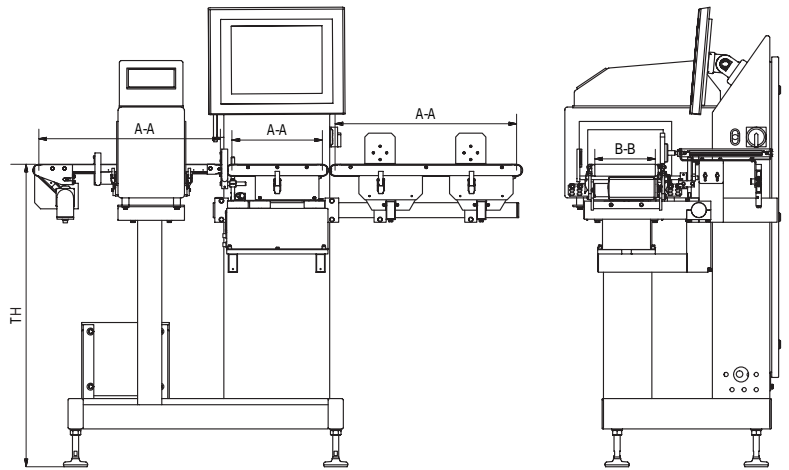

Dimension diagram XS3 CC – typical dimensions in mm

Checkweigher XS3 CC

- "Weights and Measures" design-approved in certain countries
- access protection by password
- classification in up to 7 weight zones plus "metal"
- automatic or manual re-zeroing (setting to null)
- operator prompts (dialogues) in various user-set languages

Options and accessories

- stainless steel reject catch bins and guarding
- automatic feedback to filling controllers
- statistics programs for evaluation
- various monitoring facilities (e. g. detection of product backup, rejection countercheck, successive errors detection)
- various infeed conveyors and infeed units
- various rejecting devices (e. g. air jet, drop-down conveyor, lift conveyor, lift conveyor designed as slide, line divider)
- water ingress protection "IP65 full stainless steel version"
- rejection countercheck
- additional potential-free contacts for external use of signals
- industrial network integration/various interfaces (e.g. for weight data transmission)
- GARECO remote control for controlling and data inquiry with a host PC
- CW-ReACT II for external article (product setup) management
- further options on enquiry

Metal detector

- stainless steel housing
- ICF technology allows short conveyor dimensions
- optimum detection sensitivity for the most different articles
- Auto-Balance-Control for continuous automatic adaptation to ever-changing environmental conditions
- automatic "self-teaching" sensitivity (compensation of the "product effect")
- Typical values for dry products in non-aluminium metallised packaging material:
 - Ferrous metal (Fe) $\varnothing \geq 0.8$ mm
 - Non-ferrous metal (NFe) $\varnothing \geq 1.4$ mm
 - Stainless steel (S/S) $\varnothing \geq 2.0$ mm

Weighing terminal

- touchscreen colour display, TFT 15", resolution 1024 x 768 pixel (XVGA)
- operator-friendly: TachoControl, operator prompts (menus), user profiles
- indication of all current important weighing and production data as well as configuration screens
- 200 article memory locations

Technical details, checkweigher

Roller centres, weighing conveyor (A-A)	250 to 600 mm
Roller centres, outfeed conveyor (A-A)	from 500 mm
Weighing range*	0 to 6000 g
Accuracy**	from ± 0.1 g
Line height (TH)	700 to 1100 mm (± 30 mm)
Standard rejecting device	2 pushers
Electrical ratings	115/230 V (A.C.), single-phase, 50/60 Hz, 1 kVA

* depending on design and dimensions of the weighing belt used

** depending on throughput, weight, dimensions and transport behaviour of the products

Metal detector with 1 fixed frequency range

25/100/300 kHz	B	C	D	E	F	G	H	I
width of metal detector (mm)	250	250	250	250	350	350	350	350
Pass height of metal detector (mm)	100	150	200	250	125	150	200	250
Usable height (mm)	60	110	160	210	85	110	160	210
Roller centres, infeed conveyor (A-A) (mm)	600	600	600	600	600	600	600	600
Width of conveyors (B-B) (mm)	200	200	200	200	300	300	300	300

Metal detector with 2 fixed frequency ranges

25+100/100+300/25+300 kHz	B	C	D	E	F	G	H	I
width of metal detector (mm)	250	250	250	250	350	350	350	350
Pass height of metal detector (mm)	100	150	200	250	125	150	200	250
Usable height (mm)	60	110	160	210	85	110	160	210
Roller centres, infeed conveyor (A-A) (mm)	600	600	600	600	600	600	600	600
Width of conveyors (B-B) (mm)	200	200	200	200	300	300	300	300



ΚΩΔΙΚΟΠΟΙΗΣΗ · ΙΧΝΗΛΑΣΙΜΟΤΗΤΑ · ΔΙΑΧΕΙΡΙΣΗ ΠΑΡΑΓΩΓΗΣ

Αγ. Αθανασίου 17 Τ.Θ. 76
19002 Παιανία
marketing@theodorou.gr

Τηλ: 210 6690900
Fax: 210 6640200
www.theodorou.gr

www.mt.com/garvens